

McGRATH®

Video Laryngoscope | Series 5

Operator's Manual

Doc no:
100-018-008

Revision 4.1
10th November 2006

AIRCRAFT
MEDICAL





McGRATH®

Video Laryngoscope
Series 5

Operator's Manual

Revision 4.1
10th November 2006

Document number
100-018-008

Contents

1	Introduction	2
1.1	Description	2
1.2	Accessories and Part Numbers	2
1.3	Specifications	3
1.4	Regulatory	3
2	Functional	4
2.1	Unpacking and Inspection	4
2.2	Batteries	4
2.3	Fitting the Battery	5
2.4	Fitting the CameraStick™	6
2.5	Blade Fitting	7
2.6	Blade Adjustment	8
2.7	Standby - Switching On / Off	9
2.8	Using the Laryngoscope	10
3	Maintenance and Cleaning	11
3.1	Cleaning Methods	11
3.2	Disposal of Intubation Blades	11
3.3	Handling and Product Preservation	11
3.4	Environmental	12
3.5	Maintenance	12
3.6	Troubleshooting, Replacement Parts and Repair	12
4	Warranty	15



1 Introduction

1.1 Description

The **McGRATH®** Series 5 Video Laryngoscope (“the **McGRATH®**”) is a device to aid the intubation of the trachea. A rigid laryngoscope blade restrains the tongue, allowing a clear view of the larynx and entrance to the trachea. The need to provide a guaranteed airway is fundamental to an anaesthetist’s task prior to an operation. Paramedics, A & E Consultants and General Practitioners may also be required to insert a tracheal tube in an emergency to keep the airway open where an unconscious patient is undergoing cardio-pulmonary resuscitation.

The **McGRATH®** incorporates a light source and miniature camera within the CameraStick™ assembly to view the larynx during the procedure of intubation. The image is displayed on an LCD screen mounted to the handle of the device.

A single AA 1.5V battery mounted within the handle powers the camera, display and light.

The disposable sterile blade covers the camera/light assembly.

1.2 Accessories and Part Numbers

The **McGRATH®** is not supplied with batteries or with disposable intubation blades – these should be purchased separately from your distributor.

McGRATH®	Intubation Blades (Box of 10)	550-004-000
McGRATH®	Intubation Blades (Carton of 30)	550-006-000
McGRATH®	Series 5 CameraStick™ Module	510-000-000
McGRATH®	Series 5 Handle Module	520-000-000



UNDER NO CIRCUMSTANCES SHOULD ANY OTHER TYPE OF LARYNGOSCOPE BLADE BE USED WITH THIS MEDICAL DEVICE



DO NOT OPEN ANY SEALED PART OF THE DEVICE UNDER ANY CIRCUMSTANCES. TO DO SO WILL IMPAIR THE PERFORMANCE OF THE DEVICE AND PATIENT SAFETY

McGRATH®
Video Laryngoscope
Series 5

Operator’s Manual
Revision 4.1
10th November 2006

Document number
100-018-008

1.3 Specifications

Laryngoscope Assembly

Size	200mm x 50mm x 150mm
Weight	0.7kg
Power	AA 1.5V Battery Giving typically 1 hour of non-continuous use.
Light source	High intensity LED fibre
Display	Colour LCD (1.7” diagonal)
Camera	VGA
Protection	IP65
Materials	Durable medical grade rubber, thermoplastics and stainless steel. This device and packaging are latex free.

Disposable Intubation Blade

Size	110mm x 12mm x 15mm
Material	Medical grade optical polymer
Packaging	Packaged sterile for single use only

1.4 Regulatory

This product complies with EN 60601-1 and EN 60601-1-2 safety standards. The CE mark indicates that it meets the requirements of European Council Directive 93/42/EEC concerning medical devices.



Aircraft Medical Limited operates an approved Quality Management System in accordance with BS EN ISO 13485.

“McGrath” is a registered trademark of Aircraft Medical Limited.
“Aircraft” is a registered trademark of Aircraft Medical Limited.
“CameraStick” is a trademark of Aircraft Medical Limited.

Only personnel trained in and licensed to perform intubation with a laryngoscope may use this device.

CAUTION : FEDERAL (USA) LAW RESTRICTS THIS DEVICE TO SALE BY OR ON THE ORDER OF A LICENSED PRACTITIONER

2 Functional

2.1 Unpacking and Inspection

Unpack the **McGRATH®** and check for any visible signs of damage that may have occurred during shipment. In the event of signs of damage do not use the laryngoscope, and inform the local agent or distributor.

The packaging should contain the following items:

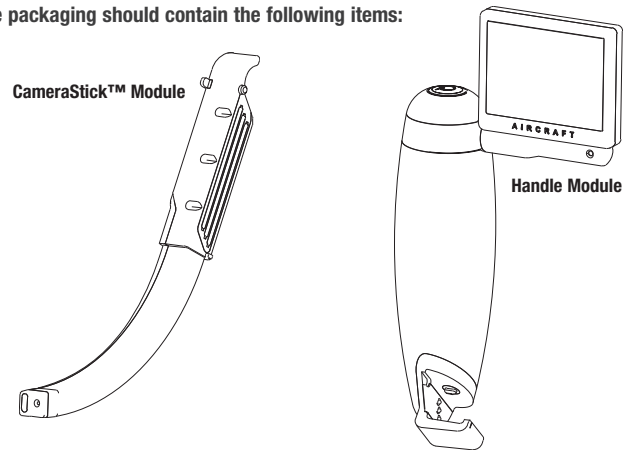

The **McGRATH®** is supplied in a non-sterile state. It will be necessary to disinfect the laryngoscope before use on a patient. (See section 3.1)

The laryngoscope blade is supplied in a sterile state. Ensure that handling precautions are taken in accordance with local, national and harmonised standards.

2.2 Batteries

For safety reasons, the batteries are not supplied with the unit. The **McGRATH®** will accept any AA battery.

McGRATH®
Video Laryngoscope
Series 5

Operator's Manual
Revision 4.1
10th November 2006

Document number
100-018-008

2.3 Fitting the battery

Locate the **handle module** and a AA battery. Unscrew (by turning anti-clockwise) and remove the **top cap** and install the battery taking care to orientate the battery as indicated on the device.

Fit the **top cap** back onto the **handle module**, making sure that it is fully tightened.

Check that the device powers up, by pushing the **STANDBY** button. When satisfied that the equipment is working correctly, re-push **STANDBY** button to switch the device to standby mode.

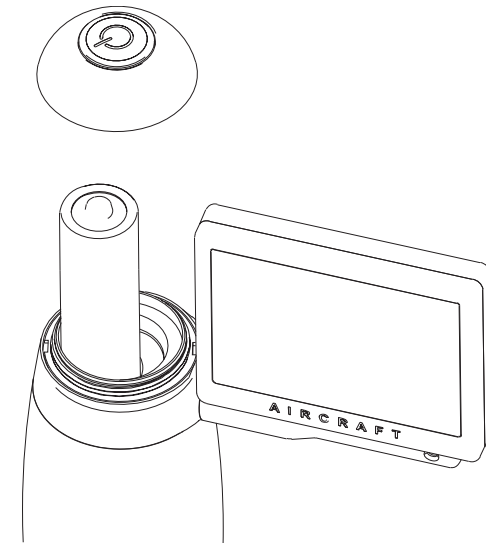

2.4 Fitting the CameraStick™

Locate the CameraStick™ module, release the **safety catch** by pulling out and rotating, then slide the CameraStick™ into the clamp at the bottom of the **handle module**. Return the safety catch to the upright position. It should be possible to hear the ratchet tooth 'clicking' as the CameraStick™ passes through the clamp. Ensure that CameraStick™ slides smoothly through the clamp whilst still requiring a reasonable amount of force to deflect the ratchet tooth.

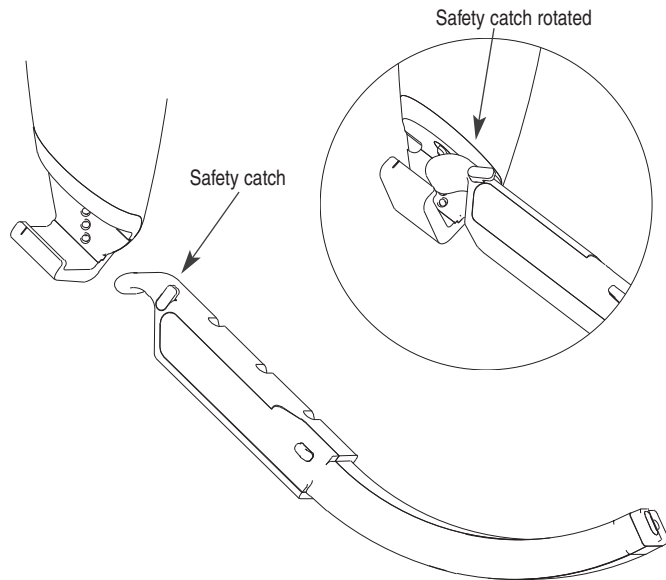

McGRATH®
Video Laryngoscope
Series 5

Operator's Manual
Revision 4.1
10th November 2006

Document number
100-018-008



2.5 Blade Fitting

The McGRATH® is designed to be used only with McGRATH® Disposable Intubation Blades.

These blades are packaged and supplied sterile and MUST be disposed of after each patient use.

To fit the blade, remove the blade from sterile packaging and slide over the CameraStick™. The blade is fully located when the blade clip is firmly latched to the CameraStick™.

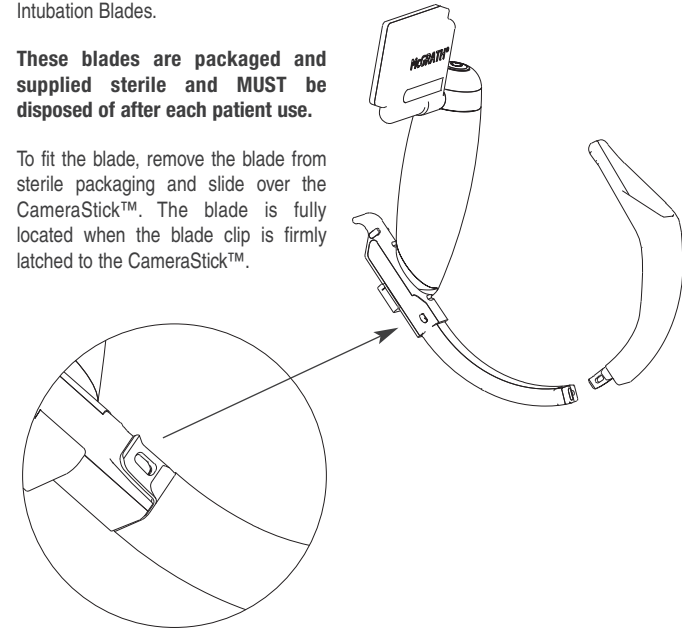

⚠️ ENSURE THAT LOCAL HANDLING PROCEDURES ARE FOLLOWED AT ALL TIMES WHILST HANDLING STERILE DEVICES

⚠️ CHECK THAT THE BLADE IS CORRECTLY FITTED TO THE DEVICE BEFORE USING ON A PATIENT

⚠️ McGRATH® BLADES MUST ONLY TO BE USED WITH A McGRATH® SERIES 5 VIDEO LARYNGOSCOPE. DO NOT ATTEMPT TO USE ANY OTHER LARYNGOSCOPE BLADE WITH THIS EQUIPMENT

⚠️ IF THERE IS ANY EVIDENCE THAT THE STERILE BARRIER ON THE BLADE PACKAGING HAS BEEN BREACHED, **DO NOT USE THE BLADE**

2.6 Blade Adjustment

The length of the blade may be adjusted for operation by sliding laterally through the clamp. The ratchet tooth grips the blade at 3 different length settings.

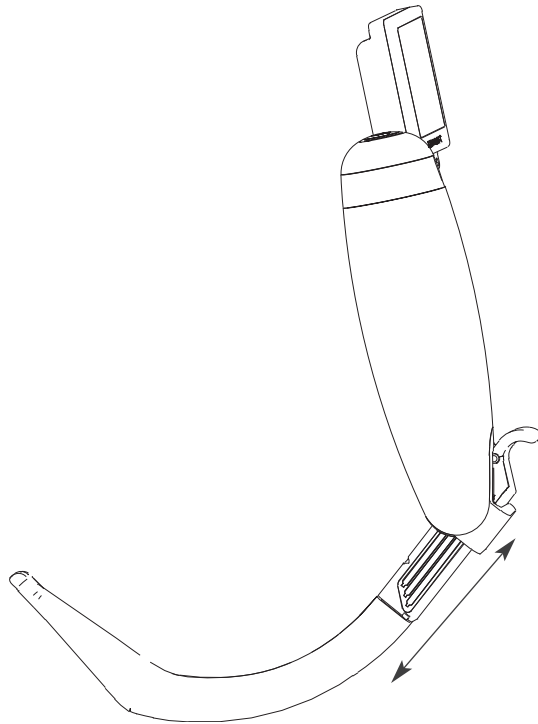

McGRATH®

Video Laryngoscope
Series 5

Operator's Manual

Revision 4.1
10th November 2006

Document number
100-018-008

2.7 STANDBY - Switching on / off

The Laryngoscope is switched on by pushing the STANDBY button. The LED on the display will light up to show that power is applied to the system. Switch the equipment to standby by pushing the STANDBY button. Ensure that the equipment is always switched to standby after use to preserve the charge in the battery.

When the unit is turned on the device automatically checks the charge state of the battery. If the battery has sufficient charge to operate, the LED on the display illuminates continuously.

When the device battery requires to be changed, the LED will begin to flash to indicate that the battery charge is low. When this occurs, it is recommended that the battery is changed IMMEDIATELY as the device will only remain operational for a very short period in this condition.

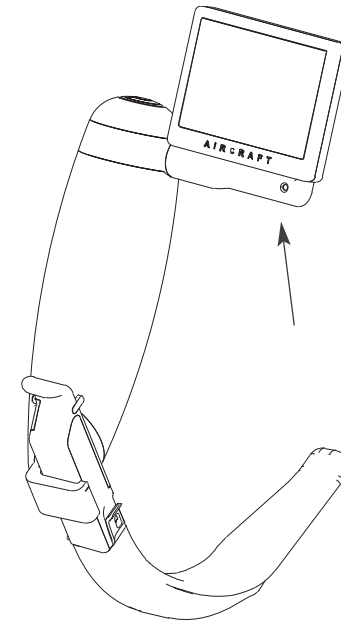

2.8 Using the Laryngoscope

The laryngoscope should be turned on as detailed in section 2.7. A bright light should appear at the tip of the CameraStick™, and an image on the screen at the top of the handle

Anaesthesia should be induced according to the anaesthetist's preference. It is not recommended that the device be used to perform awake intubation.

The tip of the laryngoscope blade should be inserted into the mouth in the midline, superior to the tongue, and rotated towards the larynx in a sagittal plane until the epiglottis is visible. Either direct vision, along the superior surface of the blade, or indirect vision via the camera, can be used to guide the laryngoscope tip toward the larynx. Care should be taken, as with conventional laryngoscopy, that the blade does not make contact with the teeth.

The tip of the blade should be guided into the vallecula. Further rotation, and/or minimal force applied along the long axis of the handle, should lift the epiglottis and allow the a view of the glottis. Again, either direct or indirect vision can be used to view the glottis.

Once the glottic opening has been correctly identified, a correctly sized tracheal tube can be passed between the vocal cords. A bougie or a malleable introducer may be used to assist the passage of the tracheal tube. If a malleable introducer is used, we recommend that a "hockey stick" curve be made at a point about 5cm from the tip of the tracheal tube.

The laryngoscope can then be carefully withdrawn by reversing the process described above. Confirmation of the correct placement of the tracheal tube should be both visual, and by the use of capnography.

McGRATH®

Video Laryngoscope
Series 5

Operator's Manual

Revision 4.1
10th November 2006

Document number
100-018-008



3 Maintenance and Cleaning



ALWAYS ENSURE THAT THE BATTERY IS REMOVED BEFORE CLEANING. THE HANDLE AND CAMERASTICK™ MUST NOT BE IMMERSUED.

3.1 Cleaning Method

3.1.1 The device should be cleaned after each patient usage. Always ensure that battery is removed when being cleaned. The unit is waterproof to a rating of IP65 and therefore NOT suitable for immersion. The device should be cleaned in accordance with local cleaning regimes for non-immersable sterile devices.

3.1.2 Dispose of all chemical disinfectants in accordance with manufacturer's guideline.



ENSURE THE DEVICE IS COMPLETELY DRY BEFORE USING



DO NOT AUTOCLAVE THIS DEVICE

3.1.3 The **McGRATH®** may be wiped with a detergent or disinfectant solution such as :
- Enzol Detergent
- Nu Cidex Disinfectant
- Cidex OPA Disinfectant

The following methods of sterilisation may be used on the **McGRATH®**.
- Tristel Sporicidal Sterilisation System
- Ethylene Oxide (EtO)

3.2 Disposal of Intubation Blades

The intubation blade must be disposed of after each procedure. The blade must be disposed of in accordance with standard departmental practices.

3.3 Handling and Product Preservation

Ensure that care is taken at all times whilst handling the device. If the device is dropped, it is recommended that you check for any visible signs of damage. If the device is showing no signs of damage but is not functioning refer to the Troubleshooting Section.

It is also recommended that the battery is removed from the device and the device returned to its original packaging when not required for use.

Avoid leaving unattended in situations where it may be misused or damaged.

3.4 Environmental

Operating Conditions:

- 10°C to 40°C ambient
- Relative Humidity 10% to 50%
- Atmospheric Pressure 700h Pa to 1060 hPa
- Category 2 Pollution Degree 2

Storage & Transport Conditions:

- -10°C to +70°C ambient
- Relative Humidity 10% to 90%

3.5 Maintenance

3.5.1 Inspection

The device should be inspected at regular intervals for:

- visible signs of external damage
- scratches or defects on the lens of the CameraStick™
- signs of deterioration of the LCD display
- build-up of material on contact strips on CameraStick™ and contact pin area of Handle

3.5.2 Product Checks

Additionally, at six month intervals the following should be checked by a qualified technician:

- check for signs of oxidization on electrical contacts
- perform the functional checks

In the event of problems the device must be returned to the distributor for repair or exchange.

3.6 Troubleshooting, Replacement Parts and Repair

Any other faults will require to be diagnosed by an authorised repair centre. The device must only be diagnosed, repaired and serviced by an official Aircraft Medical Limited distributor or agent.

Distributor Contact Details:

LMA North America, Inc
4660 La Jolla Village Drive
Suite 900
San Diego, CA 92122
(858) 587-4025
(800) 788-7999
Fax (858) 622-4130
www.LMANA.com

McGRATH®

Video Laryngoscope
Series 5

Operator's Manual

Revision 4.1
10th November 2006

Document number
100-018-008



When switched on, there is no display on the screen.

Is the battery charge LED illuminated?

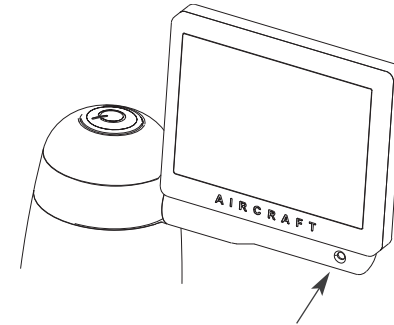

The LED is not illuminated

- Check that the battery is inserted in the correct orientation. (refer to section 2.3)
- Replace battery
- [For Service Technicians Only] Check for oxidisation on the battery contacts and, if required, clean the contacts using a fibre-pencil or similar. The unit must be cleaned after any friction type device is used on it.

LED Flashing

The LED flashing indicates that the battery requires changing.

- Change the battery

The LED is illuminated

- [For Service Technicians Only] Check the LEDs situated at the end of the CameraStick™ module. If these are not lit there may be oxidisation of the CameraStick™ or CameraStick™ clamp contact trips / pins. Clean contacts using a fibre-pencil or similar. The unit must be cleaned after any friction type device is used on it.
- [For Service Technicians Only] The unit may be receiving no signal from the camera. This also may be caused by oxidisation of the CameraStick™ or CameraStick™ clamp. Clean contacts using a fibre-pencil or similar. The unit must be cleaned after any friction type device is used on it.

If none of the above achieves positive results, return the unit to your local dealer for repair.

Poor picture quality

The image displayed on the screen is blurred or fuzzy

- Check for fogging on the intubation blade. Remove the blade and check that the image is clear and bright. If necessary wipe the camera at the end of the CameraStick™ with a clean, soft wipe.
- Check that the CameraStick™ is fully inserted in the blade and that the blade has latched to the CameraStick™ .
- [For Service Technicians Only] Clean the contact strips on the CameraStick™ and the contact pins on the CameraStick™ clamp with a fibre-pencil. The unit must be cleaned after any friction type device is on it.

The image on the screen flickers or has lines across it

- Check that the unit is fully switched on. When the unit is fully on there will be a noticeable 'click' to indicated the on switch is fully engaged
- Remove battery and check battery for oxidization
- [For Service Technicians Only] Clean the contact strips on the CameraStick™ and the contact pins on the CameraStick™ clamp with a fibre-pencil. The unit must be cleaned after any friction type device is used on it.

The image on the screen is dark or lacks contrast

- To check the contrast and brightness of the display, remove the intubation blade and check for a bright, clear picture.
- [For Service Technicians Only] If the contrast and brightness is not acceptable, replace the battery, clean the battery contacts and clean the contact strips on the CameraStick™ and the contact pins on the CameraStick™ clamp with a fibre-pencil. The unit must be cleaned after any friction type device is used on it.

If none of the above achieves positive results, return the unit to your local dealer for repair.

Loose or poorly fitting components

If any components become loose, physically damaged or fit poorly, under no circumstances use the equipment and return the unit to your local dealer for repair or replacement.

McGRATH®

Video Laryngoscope
Series 5

Operator's Manual

Revision 4.1
10th November 2006

Document number
100-018-008

4

Warranty

Aircraft Medical Limited warrants that the device supplied is, on leaving the factory, free from defects in materials or workmanship. This warranty is valid only if the product is supplied to the end user by an Aircraft approved agent or distributor and has been maintained in accordance with procedures documented in the Operator's Manual. If failure occurs from manufacturing defects within 12 months of purchase, Aircraft Medical will repair or replace the defective item.





McGRATH®

Video Laryngoscope
Series 5

Operator's Manual

Revision 4.1
10th November 2006

Document number
100-018-008



Designed & manufactured by

Aircraft Medical Ltd
10 Saint Andrew Square
Edinburgh
EH2 2AF
United Kingdom
Tel: +44 131 718 6042
Fax: +44 131 718 6100
www.aircraftmedical.com

'McGrath' and 'Aircraft' are registered trademarks of Aircraft Medical Ltd
'CameraStick' is a trademark of Aircraft Medical Ltd
International patents pending.
Copyright Aircraft Medical 2006.

McGRATH[®]

Video Laryngoscope | Series 5

