

GLIDESCOPE® Video Laryngoscopes



GlideScope® GVL® and Cobalt User's Manual



GlideScope® GVL® and Cobalt
User's Manual



Corporate Headquarters:

Verathon Inc.

20001 North Creek Parkway,
Bothell, WA 98011 USA
800.331.2313 (Canada and US)
425.867.1348
Fax: 425.883.2896
<http://www.verathon.com>

EC Rep

Verathon Medical (Europe) B.V.

Boerhaaveweg 1
3401 MN IJsselstein
The Netherlands
+31.30.68.70.570
Fax: +31.30.68.70.512
<http://www.verathon.eu>

Verathon Medical (Canada) ULC

4224 Manor Street
Burnaby, BC V5G 1B2
Canada
604.439.3009
Fax: 604.439.3039

For additional contact information please refer to page 54 or visit our corporate website: <http://www.verathon.com>.

GlideScope[®], GVL[®], GlideRite[®], Verathon[®] and Verathon Medical[®] are either trademarks or registered trademarks of Verathon[®] Inc. in the US and/or other countries.

Cidex[®] is a registered trademark of Advanced Sterilization Products, a Johnson & Johnson Company.

Manu-Klenz[®] is a registered trademark of Steris Corporation.

MetriCide[®] is a registered trademark of Suborn Dental Specialties, Inc.

Sterrad[®] is a registered trademark of Johnson & Johnson Gateway, LLC.

The GlideScope[®] technology is covered under US Patents (6,655,377) (6,543,447) (6,142,144) as well as European Patent 1307131. Additional patents pending.

Information in this User's Manual may change at any time without notice. For the latest version of this manual, refer to www.verathon.com.

Copyright © 2008 by Verathon Inc. All rights reserved. No part of this manual may be copied or transmitted by any method without the express written consent of Verathon Inc.

PN: 0900-2101-00-60

Contents

Important Information	6
Product Description.....	6
Intended Use.....	6
Notice to All Operators.....	7
Cautions	7
Introducing the GlideScope® System	9
GlideScope® System Components	10
GlideScope® GVL® System	10
Cobalt Single-Use System.....	11
GlideScope® System Setup Options.....	12
Displays, Controls, and Indicators	15
Monitor Back Panel.....	15
Monitor Front Panel.....	16
Monitor Front Panel LEDs	18
Getting Started.....	20
Initial Inspection	20
Preparing for First Use.....	21
1. Charge the Monitor Battery	21
2. Set Up the GlideScope® System	24
Setting up the GlideScope® System on the Mobile Stand.....	24
Setting up the GlideScope® System in the Hard Shell Case.....	29
Setting up the GlideScope® System on an IV Pole	31
3. Attaching and Detaching the GlideScope® GVL® or Cobalt Video Baton and GVL® Stat.....	32

Attaching the GlideScope® GVL® to the Monitor	32
Attaching the Cobalt Video Baton to the Monitor	33
Inserting the Cobalt Video Baton into the GVL® Stat.....	33
4. Connect the Monitor to an External Video Device (Optional).....	36
5. Perform a Functional Check.....	37
Clinical Application Tips	39
The Ron Walls Technique	39
Tips for GlideScope® Video Laryngoscope Insertion ...	39
Tips on Advancing the Endotracheal Tube	40
Additional Tips	42
Cleaning and Maintenance	43
General Maintenance Information.....	43
Cleaning the GlideScope® GVL®	44
Cleaning the Cobalt Video Baton.....	46
Cleaning the Monitor and Cradle	48
Cleaning the GVL® and Cobalt Video Baton Cradle	48
Cleaning the GlideRite® Rigid Stylet	48
Approved Disinfection Methods	49
Steris® System 1.....	49
Sterrad®	49
MetriCide®	49
Cidex® or Cidex® OPA.....	49
Replacing the Monitor Battery.....	50
O-Ring Replacement.....	50
Transportation and Storage	51
Device Disposal	51

GlideScope® Warranty Offerings	52
Original First Year Total Customer Care SM Warranty	52
What is Covered	53
Premium Customer Care SM Warranty.....	53
Disclaimer of Additional Warranties.....	53
Contact Information.....	54
Parts and Accessories	55
Specifications	57
General Specifications	57
Operating and Storage Conditions.....	57
GlideScope® System Components	57
Standards and Approvals.....	60
Contact Information	61
Symbol Directory	62

Important Information

Product Description

The GlideScope® Video Laryngoscope (GVL®) System incorporates a miniature, autofocusing, high-resolution color camera, an LED light source, a rechargeable lithium battery, and NTSC video output for remote display or video recording.

The GlideScope® Video Laryngoscope System is useful for anterior airways, neonatal intubations, obese patients, and patients with limited neck extension. Additionally, it is useful for teaching purposes, verification of endotracheal (ET) position, nasal intubation, and ET exchange.

The GVL® System is recommended for use with an endotracheal tube stylet, particularly the GlideRite® Rigid Stylet.

Intended Use

Statement of Prescription

Federal (USA) law restricts this device for sale by or on the order of a physician.

The GlideScope® Video Laryngoscope System should be used only by individuals who have been trained and authorized by a physician or the institution providing patient care.

Intended Use

GlideScope® Video Laryngoscopes are intended for use by qualified medical professionals to obtain a clear, unobstructed view of the vocal cords for medical procedures

Notice to All Operators

All operators should read this entire User's Manual prior to using the GlideScope® System. Failure to follow these instructions may result in patient injury, compromise the performance of the system, and may void the system warranty.

Verathon® recommends that new GlideScope® users:

- ◆ Practice using the GVL® or Cobalt on a mannequin before clinical use
- ◆ Acquire clinical experience on patients without airway abnormalities

Refer to page 39 for recommended techniques.

Cautions



Caution. Risk of permanent equipment damage. Do not expose GlideScope® Video Laryngoscopes or Cobalt Video Batons to temperatures above 140° F (60° C). Do not disinfect or sterilize GlideScope® Video Laryngoscopes or Cobalt Video Batons using devices such as autoclaves, ultrasonic cleaners, or pasteurizers. Use of such methods to disinfect/sterilize GlideScope® Video Laryngoscopes or Cobalt Video Batons will cause permanent device damage and void the warranty. Refer to page 49 for a list of approved cleaning procedures and products.



MDD Class 1 Equipment Caution: Electrical shock hazard. Refer servicing to qualified personnel.

This equipment has been tested and found to comply with the standards listed in the Approvals section of this manual (page 60). These limits are designed to provide reasonable protection against harmful interference in typical medical installations.

This equipment generates, uses, and can radiate radio frequency energy and if used properly is very unlikely to cause harmful interference to any other device(s) in the vicinity.

However, there is no guarantee that interference will not occur in a particular installation. Interference can be determined by turning the equipment on and off. If this equipment does cause interference with other devices, try to correct the interference by one or more of the following measures:

- ◆ Re-orient or relocate the receiving device
- ◆ Increase the separation between equipment
- ◆ Connect the equipment to an outlet on a circuit different from that to which the other device(s) is (are) connected
- ◆ Consult your Verathon Medical® Customer Care representative

NOTE: GlideScope® Video Laryngoscopes must be used with the supplied cables to maintain electromagnetic interference (EMI) within certified limits.

Users should be aware that portable and mobile equipment (cellular phones, etc.) can affect medical electrical equipment and take appropriate precautions during operation.

Introducing the GlideScope® System

GlideScope® Video Laryngoscopes (GVL®) are designed for “1st pass success.” They provide a consistently clear view of a patient’s airway, enabling quick intubation. GlideScope® Video Laryngoscopes are clinically proven to achieve a Cormack-Lehane Grade I or II view 99% of the time.¹

All GVL® models include an integrated, high-resolution, CMOS camera, LED light source, and a patented anti-fog mechanism. They connect directly to a color video monitor for real time viewing, video output, and recording. The GlideScope® System is available in both, reusable GVL® and single-use Cobalt versions, in a comprehensive range of versions and range of sizes, allowing clinicians to meet the particular requirements of patients ranging in size from neonatal infants to morbidly obese adults.

The GlideScope® Video Laryngoscope is an ideal tool for physicians and other healthcare professionals who need to effectively manage standard to difficult airways. The GlideScope® System is easy to learn, use, and teach. It is ideal for acute care settings and emergency environments. It also integrates easily into standard ED, OR, ICU, and NICU applications.

GlideScope® Video Laryngoscopes may be useful for the following procedures:

- ◆ First use intubations, replacing Direct Laryngoscopy (DL)
- ◆ Normal or restricted oropharyngeal views/visualization and assessment of the oropharynx
- ◆ Cormack-Lehane grades I - IV laryngeal views

1 Cooper RM. Cardiothoracic Anesthesia, Respiration and Airway; Early clinical experience with a new video laryngoscope (GlideScope®) in 728 patients. Canadian Journal of Anesthesia. 2005; 52: 2: 191–198.

- ◆ Trauma airways - excellent when dealing with blood and secretions in the airway
- ◆ Airway management in morbidly obese patients
- ◆ Preterm and neonatal intubations
- ◆ Cervical spine immobilization
- ◆ Reintubation in Intensive Care Unit (ICU) settings
- ◆ Supervision and documentation of the laryngoscopy
- ◆ Nasal tracheal intubation
- ◆ Insertion of transesophageal echocardiatic probes
- ◆ Laryngoscopic foreign body removal
- ◆ Awake intubation for difficult airway management
- ◆ Insertion of double lumen tubes
- ◆ Teaching the anatomy of the airway

GlideScope® System Components

Two interchangeable video laryngoscope systems are available: the reusable GVL® and Cobalt Single-Use System.

Please refer to page 55 for a complete listing of GlideScope® System components and part numbers.

GlideScope® GVL® System

The GlideScope® GVL® System includes:

- ◆ The GlideScope® Video Monitor
- ◆ One reusable GVL®. The GVL® is comprised of a medical-grade plastic shell that houses a high-resolution CMOS camera, LED light source, and patented anti-fogging mechanism. The GVL® device is available in four sizes. Additional units may be purchased separately.
- ◆ Video cable (connects the GVL® to the monitor)
- ◆ GlideRite® Rigid Stylet

Figure 1. GVL® System components.



Cobalt Single-Use System

The Cobalt Single-Use System includes:

- ◆ The GlideScope® Video Monitor
- ◆ Reusable video baton with integrated video cable. The Cobalt Video Baton includes a high-resolution CMOS camera, LED light source, and a patented anti-fogging mechanism. The Cobalt Video Baton is available in two sizes and each baton supports two sizes of GVL® Stats.
- ◆ GVL® Stats (sterile, single-use blades based on the current GlideScope® GVL® design) - four sizes are available
- ◆ One GlideRite® Rigid Stylet

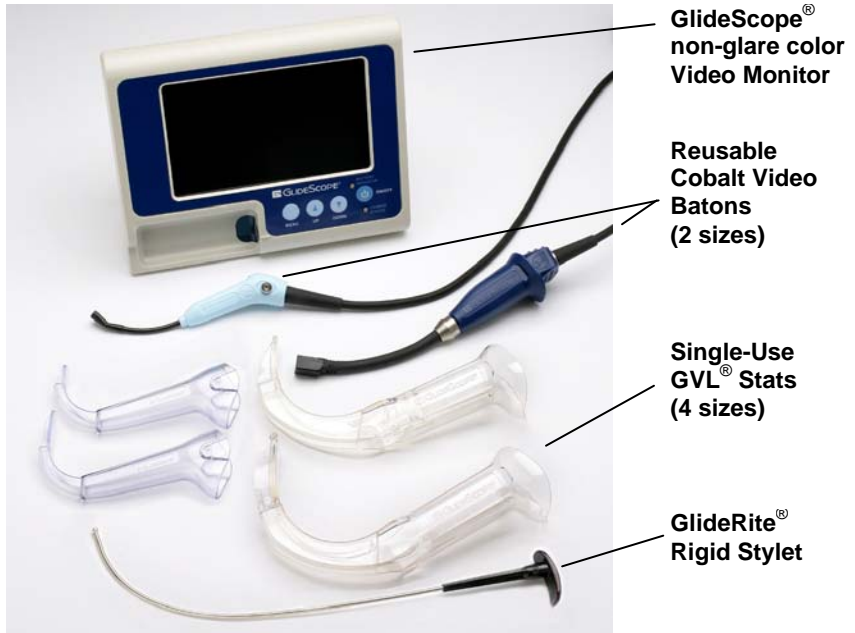
Figure 2. Cobalt Single-Use System.

GlideScope® System Setup Options

The GlideScope® Video Monitor, Video Laryngoscopes, and related accessories may be set up in various configurations in order to best meet the needs of your facility. The GlideScope® System may be:

- ◆ Mounted on a mobile stand (Figure 3)
- ◆ Secured in a hard shell case for remote or emergency applications (Figure 4)
- ◆ Mounted on an IV pole (user-supplied) for use in clinics and hospitals (Figure 5)

Figure 3. GlideScope® System - on mobile stand.

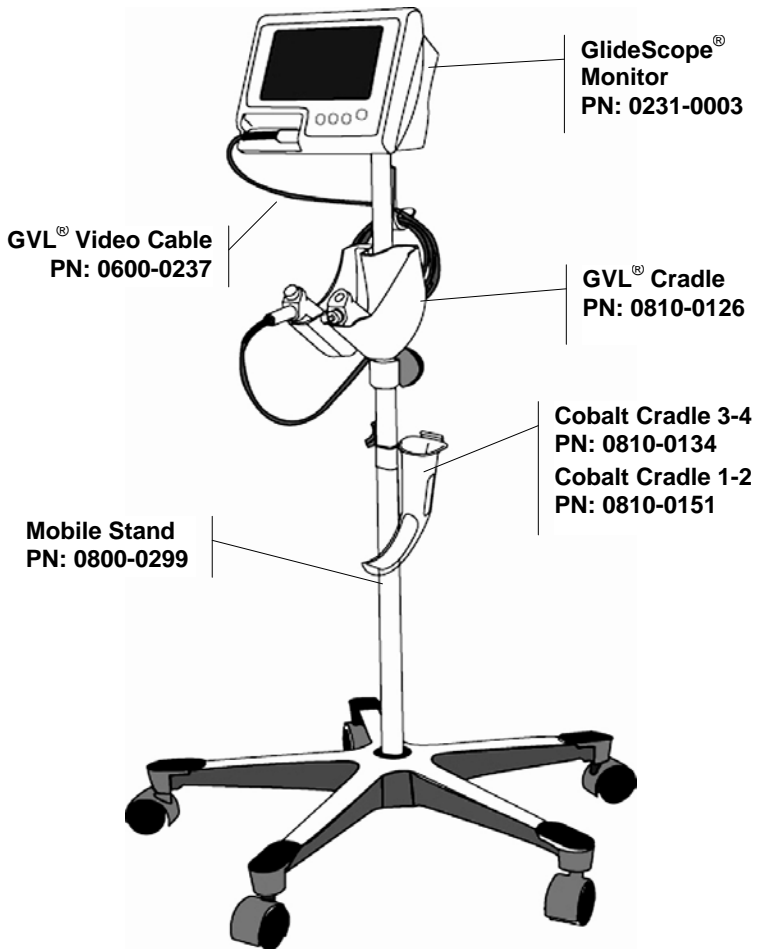

Figure 4. GlideScope® System - in hard shell case.

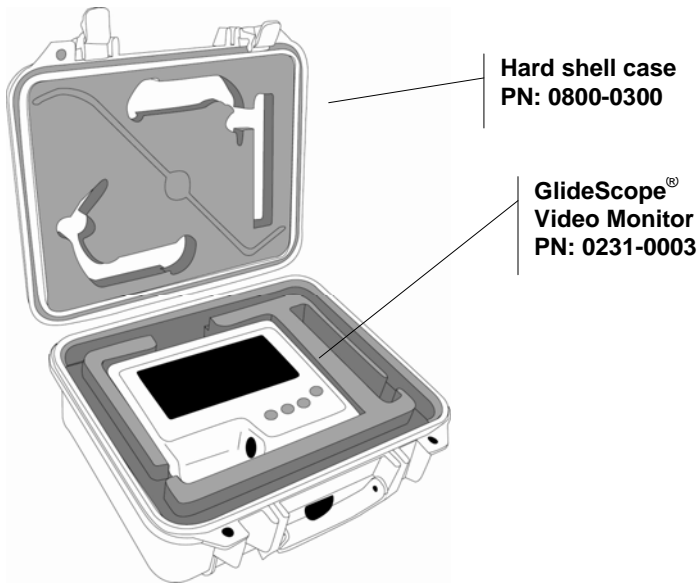
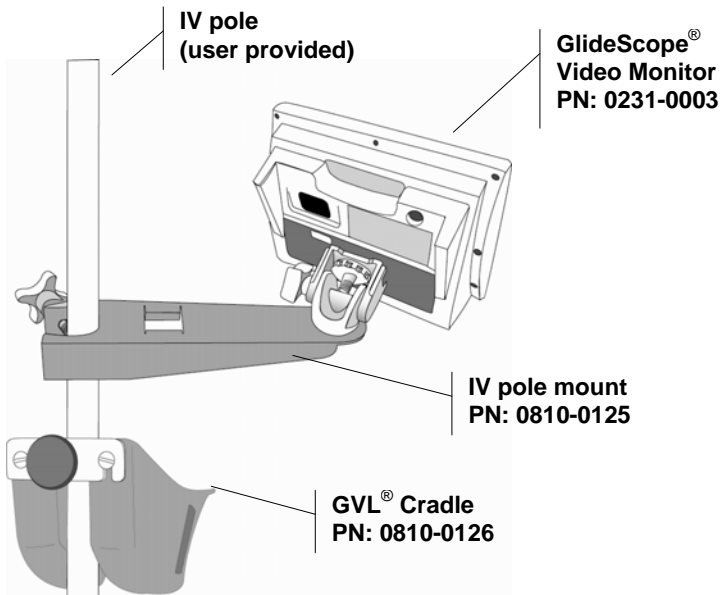

Figure 5. GlideScope® System - on IV pole (user-supplied).



Displays, Controls, and Indicators

Monitor Back Panel

The GlideScope[®] Video Monitor back panel (Figure 6) contains the power cord connector, accessory video output connector, battery ON/OFF slider switch, and a mounting point for the optional mobile stand, IV pole, or hard shell case.

Figure 6. GlideScope[®] Video Monitor back panel.

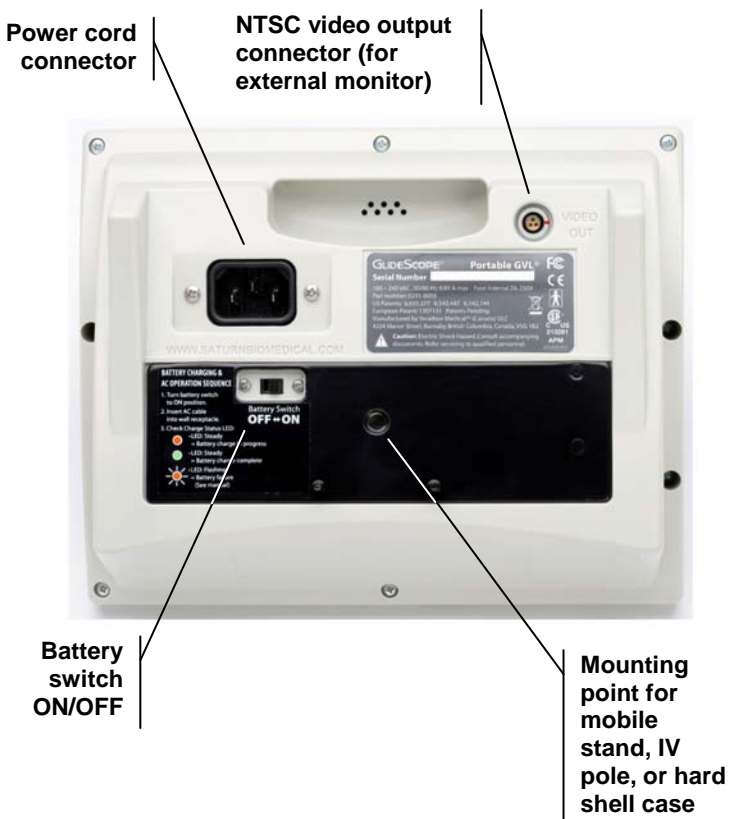

Monitor Front Panel

The GlideScope® Video Monitor front panel (Figure 7) contains the video cable connector, two battery status LEDs, and four buttons: MENU, UP, DOWN, and ON/OFF. Button functions are described in Table 1 on the next page.

Figure 7. GlideScope® Video Monitor front panel.

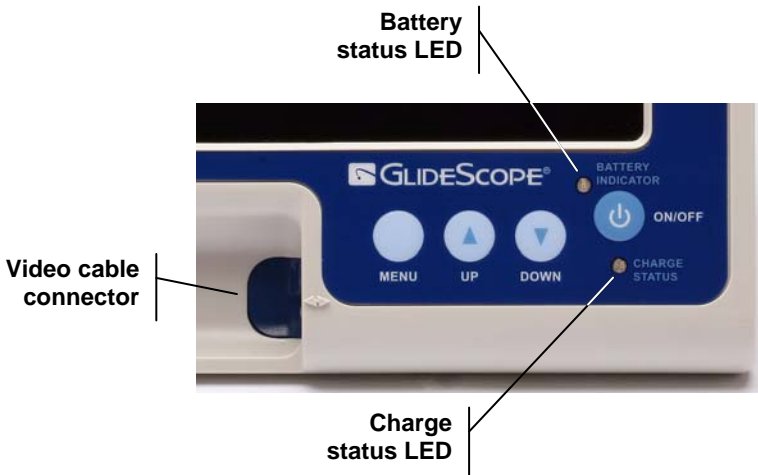





Table 1. Monitor front panel buttons.

Button	Function
 ON/OFF	Press to turn the GlideScope® System ON/OFF.
 UP DOWN	Press to increase/decrease monitor setting values.
 MENU	Press the MENU button repeatedly, to make selections from the displayed list of options. A menu item is selected (active) when highlighted in yellow. Display settings include:

Brightness: When BRIGHTNESS is highlighted, press UP/DOWN to increase/decrease luminosity. A brightness setting of 18 - 20 units is recommended.

Contrast: When CONTRAST is highlighted, press UP/DOWN to increase/decrease image contrast. A contrast setting of 16 - 20 units is recommended.

Color: When COLOR is highlighted, press UP/DOWN to increase/decrease displayed color saturation. The default setting of 50 units (on a scale of 0 - 100 units) is recommended.

Mirror: Press UP to display a mirror image of the displayed image. Press DOWN to return to the original view.

Reset: Pressing either UP or DOWN will return all monitor settings to the factory defaults.

Exit: When EXIT is highlighted, press either UP or DOWN to save all settings and return to the viewing screen.

Normal, NTSC, AV1: These three items display the format and channel of the signal that is being received from the GlideScope®. Since all GlideScope® cameras use the NTSC format, these settings will not change.

NOTE: VOLUME and MUTE may appear on some monitor screens. These features are currently inactive.

Monitor Front Panel LEDs







The monitor front panel has two status LEDs that indicate battery usage and charge states (Figure 8).

- ◆ The battery indicator LED illuminates when the monitor is operating on battery power
- ◆ The charge status LED indicates the battery charge level as explained in Table 2, on the next page

Figure 8. Front panel LEDs indicate battery usage and charge status.



Table 2. Charge status LED states.

No LED  CHARGE STATUS	The battery is completely depleted and needs to be recharged.
Steady green  CHARGE STATUS	The battery is fully charged and ready for use.
Flashing green  CHARGE STATUS	Battery power is low and needs charging. The LED flashes for approximately five minutes before shutting off.
Flashing green with beeping  CHARGE STATUS	There is approximately one more minute of battery power remaining.
Flashing orange  CHARGE STATUS	Flashing orange can indicate two states: <ul style="list-style-type: none"> ◆ If the AC power is connected and the battery switch is OFF (to the left), the charge status LED will flash orange. The monitor will still function but the battery will not charge. ◆ If the AC power is NOT connected and the charge status LED flashes orange, the battery is malfunctioning. Please consult your Verathon Medical® Customer Care representative.
Steady orange  CHARGE STATUS	Charging in progress

Getting Started

Initial Inspection

Upon receipt, inspect the components of the GlideScope® Video Laryngoscope System for any obvious physical damage that may have occurred during shipment. Verathon Medical® recommends that the inspection be performed by a biomedical engineer or other qualified professional who is familiar with electronic medical devices.

The components you receive will vary depending on which configuration was ordered (see Figure 3). To verify that you have received the appropriate components, refer to the packing list included with your system.

If any of the components are missing or damaged, notify the carrier and Verathon Medical® Customer Care immediately at:

- ◆ 800.331.2313 (Canada and US)
- ◆ 425.867.1348 (International)
- ◆ +31.30.68.70.570 (Europe)

Please refer to page 54 for additional contact information,

Preparing for First Use

Prior to using the GlideScope® System for the first time, perform the following steps:

1. Charge the monitor battery (instructions begin on this page).
2. Set up the GlideScope® System in your preferred configuration (instructions begin on page 24).
3. Attach a video laryngoscope to the monitor (instructions begin on page 32).
4. Connect the monitor to an external source such as a TV screen or NTSC video monitor (optional).
5. Perform a functional check (instructions begin on page 37).

1. Charge the Monitor Battery

The GlideScope® System can operate on AC power (wall current) or battery power.

The GlideScope® Monitor contains a lithium battery that provides power to the GlideScope® Video Laryngoscope. Under normal conditions, the battery will last approximately 90 minutes before it needs to be recharged.

IMPORTANT! The battery must be fully charged prior to first use.

For optimal battery life:

- ◆ The battery must be fully charged before first use in battery mode
- ◆ When the battery is low, the charge status LED (on the monitor front panel) will flash green for approximately five minutes

- ◆ When the battery is nearly depleted, the charge status LED will flash green and beep. This indicates that the battery has approximately one minute of power remaining.
- ◆ The monitor battery should be charged at room temperature, between 32° - 104° F (0° - 40° C)

To charge the monitor battery:

IMPORTANT! Before beginning, make sure the AC power cord is disconnected and the battery switch (on the monitor rear panel) is in the OFF position (to the left).

1. Slide the battery switch to the ON position (to the right) (Figure 9).
2. Insert the female end of the power cord into the power cord connector on the back of the monitor (Figure 9).

Figure 9. Rear panel detail: AC power cord connector and battery switch in the ON position.

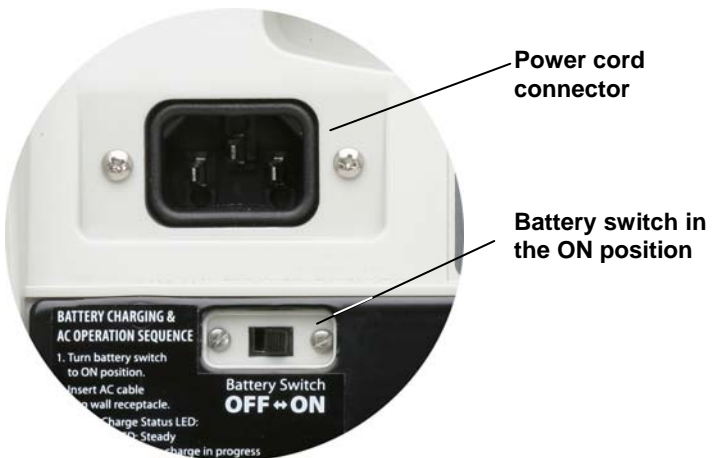

3. Insert the other end of the power cord into a wall outlet or appropriate AC power source.

NOTE: For power supply compatibility information, please refer to the label on the back of the monitor.

4. The charge status LED will turn orange, indicating that the charging cycle has begun. When the battery is fully charged, the charge status LED will turn green (Figure 10).

At this point the system is fully functional on battery power.

Figure 10. The charge status LED will turn green when the battery is fully charged.



NOTE: For more information about charge status LED states, refer to Table 2 on page 19.

2. Set Up the GlideScope® System

The GlideScope® System may be set up in one of three configurations:

- ◆ On a mobile stand (Figure 3)
- ◆ In a hard shell case (Figure 4)
- ◆ On an IV pole (Figure 5)

Setting up the GlideScope® System on the Mobile Stand

(Refer to Figure 3, page 13)

Attach the center pole to the base (mobile stand only)

1. Remove the hex bolt and washers from the bottom of the pole.
2. Insert the bottom end of the pole into the top of the base.
3. Flip the base over and screw the bolt and washers back into place to secure the pole to the base. To keep the center pole stable, be sure to tighten the bolt securely.

Figure 11. Attaching the mobile stand base to the center pole - hardware stack-up.

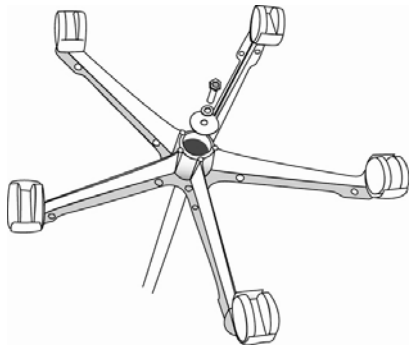

4. To reinsert the mobile stand wheels: insert the wheel pin into the opening on the end of the mobile stand base (Figure 12). Applying steady, moderate force, press the wheel pin into the base until it snaps into place.

To Remove the Mobile Stand Wheels

The mobile stand wheels may be removed to facilitate storage and transportation.

Using steady, moderate force, pull the wheels away from the base.

Figure 12. Removing and inserting the wheels from the mobile stand.

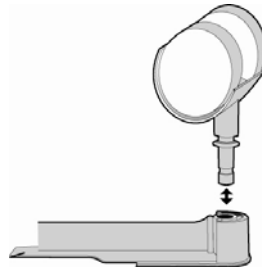

Adjust the Height of the Mobile Stand (Figure 13)

1. Loosen the black height adjustment knob located on the mobile stand pole by turning it counterclockwise.
2. Raise or lower the pole to the desired height.
3. Secure the pole in position by turning the height adjustment knob clockwise.

Figure 13. Adjusting the height of the mobile stand.



Attach the Monitor to the Mobile Stand

Hold the monitor against the screw on the tilt head and turn the tilt head fastener clockwise to tighten (Figure 14).

Adjust the Monitor Angle

Before use, the angle of the monitor should be adjusted for optimal viewing. The ideal angle will be determined by the working position of the monitor and the user.

To adjust the angle of the monitor:

1. Loosen the angle adjustment knob located on the tilt head of the IV pole mount by turning it counterclockwise.
2. Tilt the monitor to the desired angle.
3. Secure the monitor in place by turning the angle adjustment knob clockwise (Figure 14).

Figure 14. Attaching the monitor to the mobile stand.

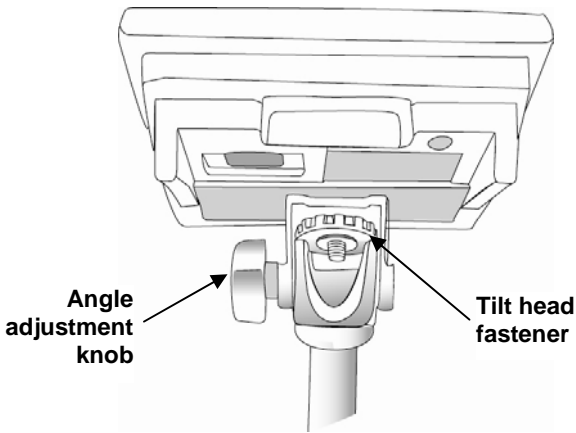

Attach the GVL[®] Cradle

To attach the GVL[®] Cradle:

1. Open the cradle latch and position the mobile stand pole on the back of the cradle.
2. Close the cradle latch and tighten in place by turning the black cradle adjustment knob clockwise (Figure 15).

Figure 15. Attaching the GVL[®] Cradle to the mobile stand.

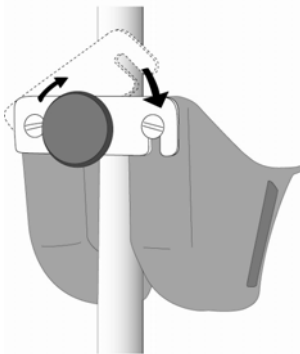
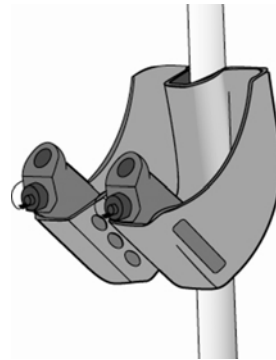

Figure 16. GlideScope[®] GVL[®]s in the cradle bays.



Attach the Cobalt Video Baton Cradle

The Cobalt Video Baton Cradle may be mounted either to the GVL® Cradle or directly to the mobile stand center pole. Directions for mounting to the center pole begin on page 28.

To attach the Cobalt Video Baton Cradle to the GVL® Cradle:

1. Attach the GVL® Cradle to the mobile stand as shown in Figure 15.
2. Hook the Cobalt Cradle into the GVL® Cradle as shown in Figure 17.

Figure 17. Attaching the Cobalt Video Baton Cradle to the GVL® Cradle.

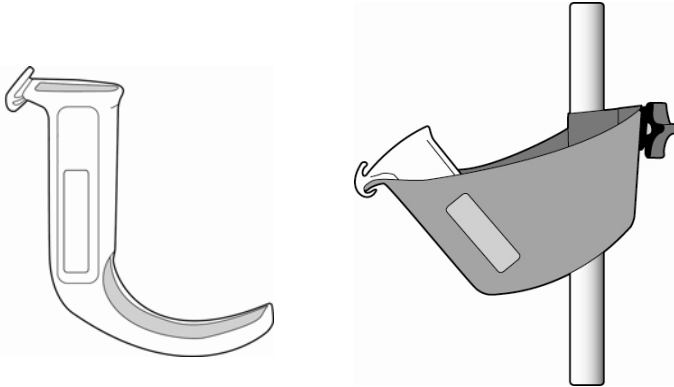

To attach the Cobalt Video Baton cradle directly to the mobile stand or IV pole:

1. Attach the center pole clamp to the Cobalt Cradle.
2. Attach the center pole clamp and Cobalt Video Baton Cradle to the mobile stand or IV pole and turn the black knob clockwise to tighten.

Figure 18. Attaching the center pole clamp to the Cobalt Cradle.

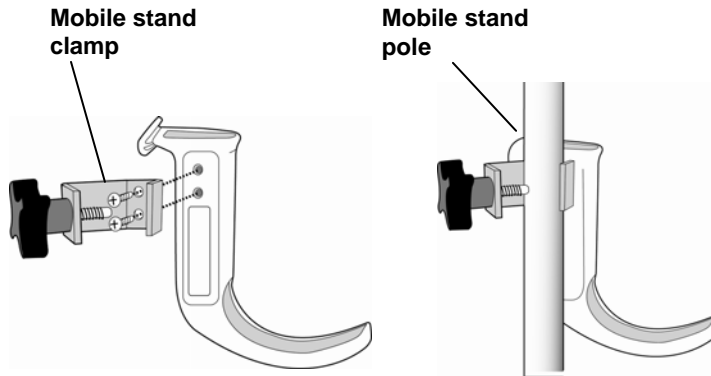

Setting up the GlideScope® System in the Hard Shell Case

Refer to Figure 19 page 30.

The hard shell case comes with a custom foam insert designed to protect the GlideScope® System components. To secure the monitor in the hard shell case:

1. Remove the foam insert from the bottom of the hard shell case.
2. Remove the screw from the foam insert.
3. Align the foam insert with the monitor rear panel so that the battery switch remains accessible.
4. Screw the foam insert to the monitor until the screw is snug (Figure 19). Do not over-tighten the screw.

Figure 19. Removing the video monitor from the hard shell case.

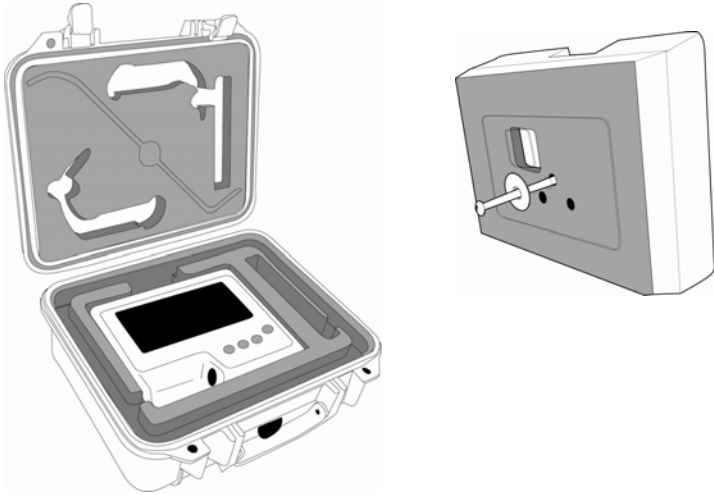

Removing the Video Monitor From the Hard Shell Case

To remove the monitor from the hard shell case:

1. Grasp the monitor handle and pull the monitor and foam out of the hard shell case.
2. On the back of the foam insert, remove the screw holding the monitor to the foam.

Setting up the GlideScope® System on an IV Pole

Refer to Figure 5, page 14.

1. Attach the IV pole mounting bracket to the IV pole by tightening the bracket attachment knob until the bracket is secure.
2. To attach the GlideScope® Video Monitor: hold the monitor against the screw on the tilt head and turn the tilt head fastener clockwise to tighten (Figure 14).

Figure 20. Attaching the mounting bracket to the IV pole.

Bracket attachment knob

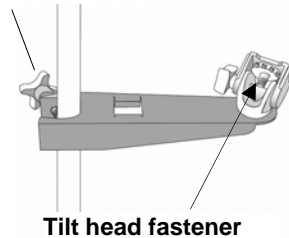

3. To attach a GVL® Cradle to the IV pole, refer to Figure 15.

To attach a Cobalt Video Baton Cradle to the IV pole refer to Figure 17 or Figure 18.

3. Attaching and Detaching the GlideScope® GVL® or Cobalt Video Baton and GVL® Stat

Attaching the GlideScope® GVL® to the Monitor

The GlideScope® GVL® connects to the monitor with a detachable video cable (supplied).

1. Insert the GVL® Video Cable into the connector port located on the face of the monitor so that the arrows on the cable and the monitor are aligned (Figure 21).

NOTE: When connecting and disconnecting the cable, grasp the connector by the gray sleeve.

Figure 21. Attaching the GVL® Video Cable to the monitor.

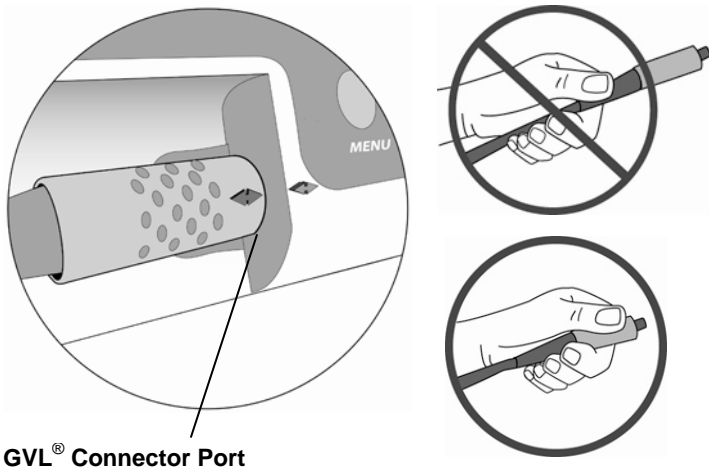

2. Insert the other end of the cable into the port located on the handle of the GVL® (Figure 22).

Figure 22. Attaching the video cable to the monitor and GVL®.

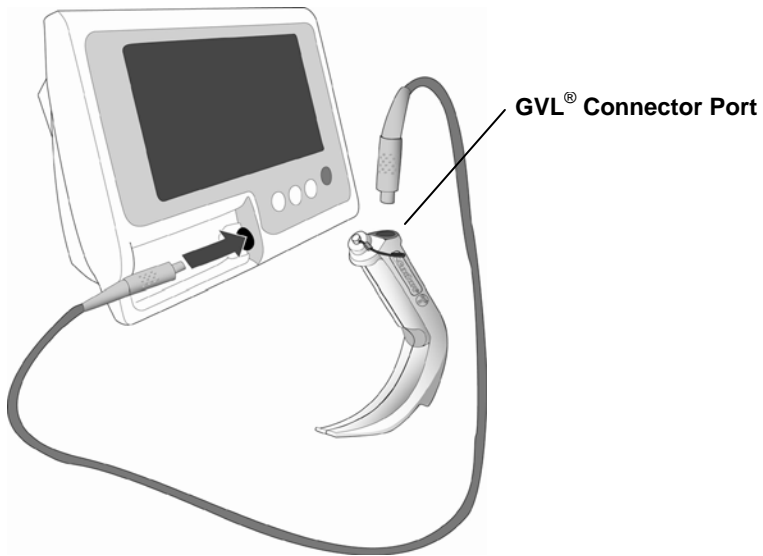

NOTE: Visually inspect the GVL® to assure that all surfaces are free of unintended rough areas, sharp edges, protrusions, or cracks.

Attaching the Cobalt Video Baton to the Monitor

The Cobalt Video Baton includes an integrated video cable. To attach it to the monitor, insert the video cable connector into the port located on the face of the monitor so that the arrows on the cable and the monitor are aligned as shown in Figure 21.

NOTE: When connecting and disconnecting the connector cable, grasp the cable by the gray sleeve (Figure 21).

Inserting the Cobalt Video Baton into the GVL® Stat

The Cobalt reusable Video Baton is used with a sterile, single-use, GVL® Stat.

- ◆ Cobalt Video Baton 1-2 is used with GVL® Stats 1 and 2
- ◆ Cobalt Video Baton 3-4 is used with GVL® Stats 3 and 4

To insert the Cobalt Video Baton into the GVL® Stat:

1. Insert the Cobalt Video Baton into the GVL® Stat until it clicks into place (Figure 23).

Figure 23. Inserting the Cobalt Video Baton into the GVL® Stat.

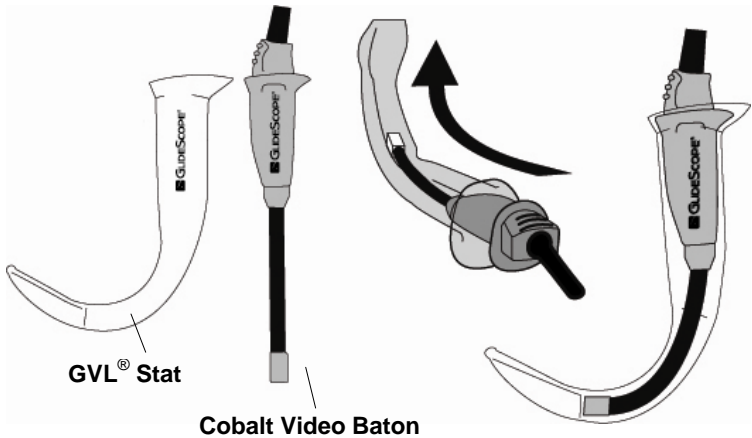

2. Ensure proper insertion by aligning the wide collar of the video baton to the wide collar of the GVL® Stat; or match the GlideScope® logo on the side of the video baton with GlideScope® logo on the side of the GVL® Stat.

Be sure not to insert the video baton backwards (Figure 24). If the video baton does become stuck, insert a tongue depressor into the GVL® Stat shell to release the video baton.

Figure 24. Do not insert the video baton backwards.

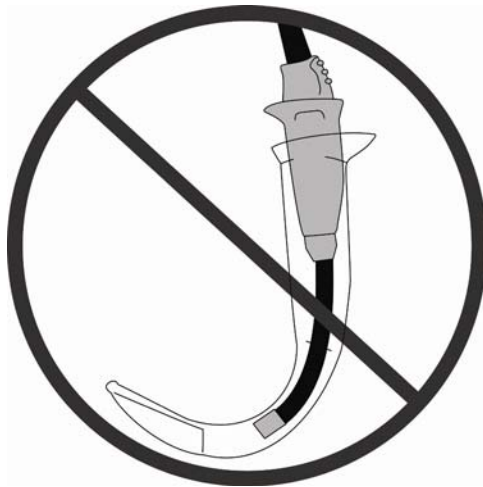

NOTE: Visually inspect the GVL® Stat to ensure that all exterior surfaces are free of unintended rough areas, sharp edges, protrusions, or cracks.

Detaching the Cobalt Video Baton from the GVL® Stat

The GVL® Stat is a single-use device. After each use, it should be removed from the Cobalt Video Baton and disposed of properly.

To detach the Cobalt Video Baton from the GVL® Stat, grasp the handle of video baton and pull firmly (Figure 25).

Figure 25. Detaching the video baton from the GVL® Stat.

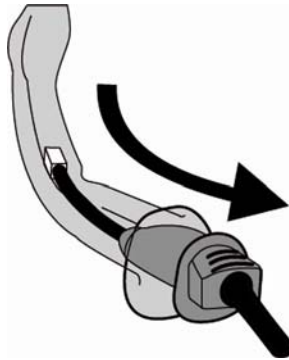

IMPORTANT! A used GVL® Stat is a biohazard and should be disposed of in a manner consistent with local directive's in the user's jurisdiction.

4. Connect the Monitor to an External Video Device (Optional)

The monitor may be connected to an NTSC-compatible external device such as a TV screen or video recorder by using an optional Verathon® video output cable. Please contact your Verathon Medical® Customer Care Representative for more information.

To connect the monitor to an external video device:

1. Insert the video output cable into the port on the back of the video monitor.
2. Connect the opposite end of the cable to the external viewing device.

Figure 26. Attaching a video output cable to the monitor.

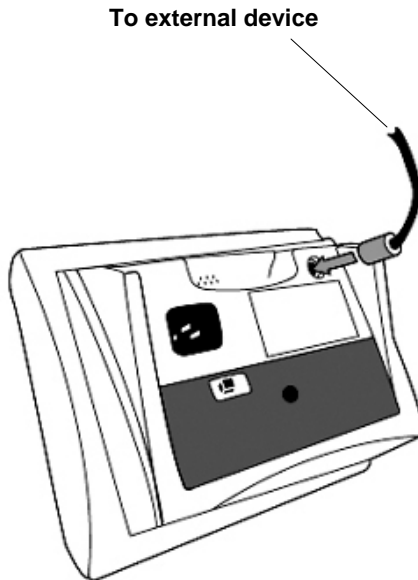

5. Perform a Functional Check

Prior to first use, perform the following functional check to assure that the GlideScope® System is working properly. Please contact your Verathon Medical® Customer Care Representative if your GlideScope® System does not function as described below.

To perform a functional check of the GlideScope® System:

1. Fully charge the monitor battery (see page 21).
2. Connect a GlideScope® Video Laryngoscope to the monitor (GVL® or Cobalt Video Baton + GVL® Stat, see page 32).
3. Slide the battery switch on the back of the monitor to the ON (to the right) position.

4. Turn the system on by pressing the ON/OFF button located on the face of the monitor.
5. Observe the monitor screen to verify that an image is being received from the GlideScope® (Figure 27).

NOTE: The upper left corner of the LCD screen will display a small portion of the GVL® Blade (Figure 27). The blade is captured in the view due to the wide-angle properties of the camera lens. This opaque portion acts as a frame of reference during the intubation process and assures that the orientation of the image is correct in the monitor.

Figure 27. When the power is on, one corner of the GVL® blade is visible in the display.

**Portion of GlideScope®
blade (frame of reference)**

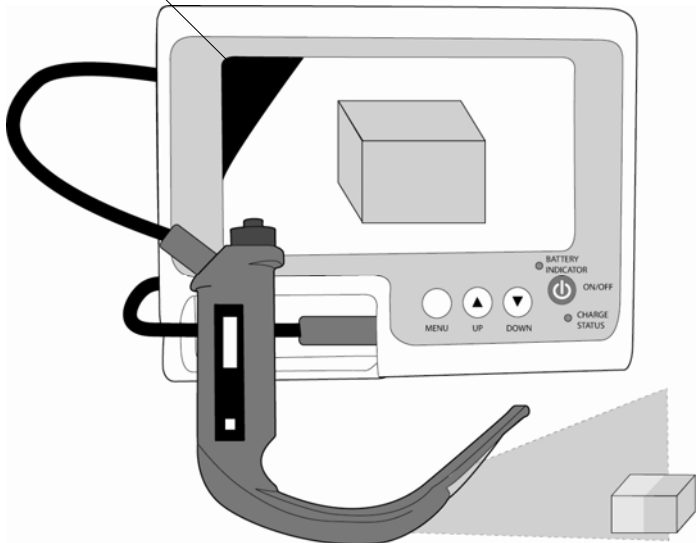

Clinical Application Tips

The Ron Walls[†] Technique

1. First look at the patient's **mouth** directly when introducing the GlideScope® GVL® into the midline of the oral cavity.
2. Then look at the **monitor** and elevate the tip of the blade to see the epiglottis and the glottic opening.
3. Next, look at the **mouth** to carefully guide the tube and stylet into position near the tip of the laryngoscope.
4. Then look back at the **monitor** to complete the intubation under direct vision.

Tips for GlideScope® Video Laryngoscope Insertion

1. Verathon Medical® recommends inserting the GlideScope® GVL® down the midline of the tongue to the epiglottis.
2. The GlideScope® GVL® may be used to produce a Macintosh indirect lift of the epiglottis or a Miller lift.
3. Intubations using the GlideScope® GVL® only require approximately 1 to 3.5 lbs (0.5 - 1.5 kgs) of lifting force.

† Ron M. Walls, M.D., Chairman - Department of Emergency Medicine, Brigham and Woman's Hospital, Professor of Medicine (Emergency Medicine), Harvard Medical School.

4. Verathon Medical® recommends a 90° angle for the endotracheal tube stylet and an ET tube with a soft distal tip. The GlideRite® Rigid Stylet is specifically designed to complement the angulation of the GVL® to facilitate intubation.
5. To aid the passage of the endotracheal tube, withdraw the stylet approximately 2 inches (5 cm) and withdraw the GlideScope® GVL® approximately 1/2 inch (1 - 2 cm).

Tips on Advancing the Endotracheal Tube

1. Select a stylet.

The GlideRite® Rigid Stylet is designed to complement the angulation of the GVL® or GVL® Stat and requires no bending or other manipulation (Figure 28).

Use of the GlideRite® Rigid Stylet enhances the ease and speed of endotracheal procedures.

Figure 28. The curvature of the GlideRite® Rigid Stylet complements that of the GVL® and GVL® Stat.



If using another type of malleable stylet, Verathon® recommends bending the tip of the stylet to at least 90° to complement the angle of the GVL® or GVL® Stat. An angle larger than 90° may increase the difficulty of advancing the endotracheal tube.

2. Introduce the endotracheal tube.

- ◆ The endotracheal tube should be introduced behind or immediately adjacent to the GVL® or GVL® Stat
- ◆ The stylet should not enter the larynx during intubation
- ◆ The proximal tip of the stylet may be bent backward to permit one-handed operation of the endotracheal tube (Figure 29)
- ◆ The proximal end of the endotracheal tube should be carefully introduced between the vocal folds
- ◆ The operator should take care not to damage the cuff, teeth, or oropharynx during insertion

3. Withdraw the stylet 2 in (5 cm).

Using the right hand, advance the endotracheal tube while simultaneously withdrawing the stylet with the thumb (Figure 29). The stylet should be withdrawn approximately 2 in (5 cm). This straightens the tip of the endotracheal tube and permits it to enter the larynx while the stylet continues to provide rigidity to the body of the endotracheal tube.

Figure 29. The GlideRite® Rigid Stylet is designed for one-handed removal from the endotracheal tube.



Removing the rigid stylet from the endotracheal tube

Additional Tips

New GlideScope® users often achieve an excellent view with the GVL® or GVL® Stat but may experience some difficulty advancing the endotracheal tube. This may be caused by two factors:

- ♦ **Excessive lifting or pushing of the glottis by the GVL® or GVL® Stat**
Maximum laryngeal exposure may not facilitate intubation; reducing the elevation applied to the laryngoscope may make inserting the endotracheal tube easier.
- ♦ **Angulation of the tip of the endotracheal tube**
The GlideRite® Rigid Stylet is designed to complement the angulation of the GVL® or GVL® Stat.

Cleaning and Maintenance

General Maintenance Information

Periodic inspections should be performed to ensure safe and effective operation. It is recommended that a qualified technician perform a full visual inspection of all components at least every three months.

The technician should check for the following items:

- ◆ External damage
- ◆ Damage to the power supply
- ◆ Connectors and cable insulation integrity

To ensure patient safety, users should perform a routine inspection of the GlideScope® Video Laryngoscope before every use to ensure that all endoscopic components are free of unintended rough surfaces, sharp edges, protrusions or cracks.

If inspection reveals any faults in the components, contact Verathon Medical® Customer Care. All repairs must be performed by an authorized Verathon Medical® Service Center.



Caution. Risk of permanent equipment damage.
Do not expose GlideScope® Video Laryngoscopes or Cobalt Video Batons to temperatures above 140° F (60°C). Do not disinfect or sterilize GlideScope® Video Laryngoscopes or Cobalt Video Batons using devices such as autoclaves, ultrasonic cleaners, or pasteurizers. Use of such methods will cause permanent device damage and void the warranty. Refer to page 49 for a list of approved cleaning procedures and products.

Cleaning the GlideScope® GVL®

The GlideScope® GVL® is a non-sterile reusable device. To avoid cross-contamination, the GlideScope® Video Laryngoscope must be disinfected immediately after each use.

- ◆ Do not place the GlideScope® GVL® in the cradle, in the hard shell case, or other storage until all cleaning procedures have been completed

During cleaning, take care to avoid overheating. Monitor the color of the temperature gauge on the GVL® handle to avoid overheating the GVL® (Figure 30).

- The temperature indicator turns black if the GVL® is heated above 140° F (60° C).
- A gray indicator does not indicate overheating.
- The temperature indicator is white when the GVL® is at room temperature.

Figure 30. Monitor the color of temperature indicator to avoid overheating the GVL®.

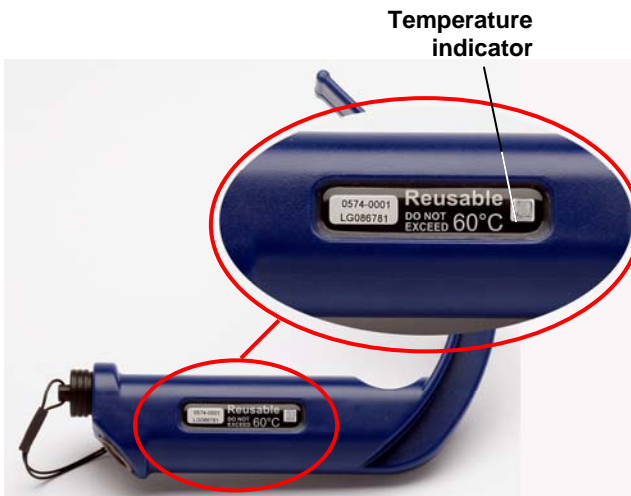

**Caution: Risk of equipment damage.**

The temperature indicator turns black when the GVL[®] is exposed to temperatures above 140° F (60° C).

Caution: Risk of equipment damage.

Failure to cover the cable connector port with the protective cap prior to cleaning may result in water ingress and potential device failure.

To clean the GlideScope[®] GVL[®]:

1. Disconnect the GlideScope[®] from the video cable.
2. Insert the attached protective cap into the video cable port to protect the electronic connector as shown in Figure 31.

Figure 31. Place the protective cap over the video cable port before cleaning the GVL[®].

Protective cap in
“standby” position



Correct cleaning position -
protective cap covering the
electronic connector



3. Wash the GVL® manually with a detergent such as Manu-Klenz® or an enzymatic debridement agent such as Medzyme to remove all foreign material from the surface of the device. This allows the active ingredients of the chosen process to reach all of the surfaces of the device.
4. Use a high-level disinfection process approved by the FDA, Health Canada, or other international standards. Consult the list of approved disinfection methods beginning on page 49 or contact your Verathon Medical® Customer Care representative for more information.

Cleaning the Cobalt Video Baton

The Cobalt Video Baton may be cleaned with a 70% isopropyl alcohol wipe between uses, or disinfected as needed. The Cobalt Video Baton may be placed in the Cobalt Cradle after the GVL® Stat has been removed.

When required, the GlideScope® Cobalt Video Baton can be put through a full cleaning process as follows:

To clean the Cobalt Video Baton:

1. Detach the GVL® Stat from the Cobalt Video Baton as described on page 35.

NOTE: A used GVL® Stat is a biohazard and should be disposed of in a manner consistent with local protocols.

2. Disconnect the Cobalt Video Baton from the monitor.
3. Place the protective cleaning cap over the connector as shown in Figure 32.

Figure 32. Place the protective cleaning cap over the connector as shown.



Correct cleaning position - protective cap covering the electronic connector

4. Wash the Cobalt Video Baton manually with water to remove all foreign material from the surface of the device.
5. The Cobalt Video Baton will not be damaged if it is immersed in water, the Steris 20 Sterilant used in the Steris® System 1 Sterile Processing System, or if it is wiped with 70% IPA. After removal, store the video baton in a clean environment.



Caution: Risk of equipment damage.

Do not use bleach on the Cobalt Video Baton. Bleach will corrode the stainless steel inserts.

Cleaning the Monitor and Cradle

Clean the exterior of the monitor and the cradle with IPA (70% Isopropyl Alcohol Solution) wipes.

Cleaning the GVL® and Cobalt Video Baton Cradle

Wipe the cradle with a standard hospital-grade surface cleaning product.

Cleaning the GlideRite® Rigid Stylet

1. Remove excess soil by wiping with disposable cloth or rinsing and brushing.
2. Using a brush, apply detergent such as Manu-Klenz® or an enzymatic debridement agent such as Medzyme to all surfaces.

NOTE: Do not clean in chlorine solution. Stainless steel does not resist chlorine in high concentrations.

3. Rinse under clean, running water for 1 minute.
4. Disinfect the GlideRite® Rigid Stylet by using one of the following approved products and methods:
 - ◆ Autoclave
 - ◆ Steris®
 - ◆ Sterrad®
 - ◆ MetriCide®
 - ◆ Cidex®

Products and methods mentioned above should be used according to manufacturer's specifications.

Approved Disinfection Methods

The following high-level disinfectants are approved for use:

NOTE: Read and comply with product use instructions in all applications.

Steris[®] System 1

Place the GVL[®] or Cobalt Video Baton in the Steris[®] System 1 machine and begin the cleaning cycle as instructed by Steris[®]. After removal, the GVL[®] or Cobalt Video Baton should be kept in a clean environment.

NOTE: Steris[®] systems that use steam should NOT be used to sterilize the GVL[®] or Cobalt Video Baton.

Sterrad[®]

Dry the GVL[®] completely after preliminary cleaning. Complete the cleaning cycle according to the directions provided by Sterrad[®].

MetriCide[®]

Immerse the GVL[®] in MetriCide[®] for 20 minutes to complete the requirement. Rinse with sterilized water. After cleaning, thoroughly dry the blade with a clean towel (paper or cloth). Store in a clean environment.

Cidex[®] or Cidex[®] OPA

The Cidex[®] OPA preparation requires 12 minutes of immersion to provide high level protection suitable for laryngoscopes. Immerse the GVL[®] in Cidex[®] OPA or Cidex[®] Standard for 12 minutes to complete the requirement. Following disinfection, rinse with sterilized water, dry and store in a clean environment.



Caution: Risk of equipment damage.

Do not use bleach on the Cobalt Video Baton. Bleach will corrode the stainless steel inserts.

Availability of disinfection products varies by country, and we are unable to test products in every market. Please use the list of recommended disinfectants in this manual to compare with products available locally. If you are uncertain about the suitability of a disinfectant, please contact Verathon Medical® Customer Care or your local Verathon® GlideScope® Representative.

Replacing the Monitor Battery

Under normal operating conditions, the battery will last 2 - 3 years; or approximately 500 charge/discharge cycles.

The battery is not user-replaceable. In case of battery malfunction, do not attempt to replace the monitor battery. **Any attempts to replace the battery by unauthorized service technicians will void the warranty.** Please contact your Verathon Medical® Customer Care Representative for more information on battery replacement.

O-Ring Replacement

A protective cap is attached to the top of the GlideScope® GVL® and on the end of the Cobalt Video Baton cable. The protective cap contains a rubber O-ring that ensures an effective seal during cleaning and sterilization. Over time, routine use will wear out the O-ring. Replace the O-ring immediately if:

- ◆ Any nicks or tears are visible
- ◆ There is any liquid in the cable connector port after cleaning

To replace an O-ring:

1. Remove the protective cap from the GVL® port.
2. On the inside of the protective cap, pick the O-ring out of the groove located at the base of the cap and remove.
3. Then stretch the replacement O-ring around the base of the cap and insert it into the groove (Figure 33). Make sure it is seated securely in the groove. Take care not to nick the O-ring during insertion.

Figure 33. Replacing the O-Ring.

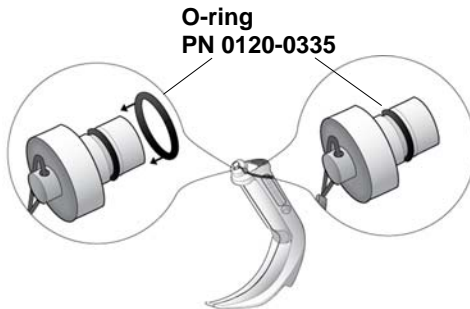

Transportation and Storage

GlideScope® System components can be safely used and stored under the following environmental conditions:

- ◆ Relative humidity range of 10 - 90%
- ◆ Storage temperature range of 32° - 113° F (0° - 45° C)

Figure 34. Prior to shipping, make sure the battery switch is in the OFF position.



IMPORTANT: The battery switch must be in the OFF (left side) position during shipping and storage.

Device Disposal

Disposal of this device can be coordinated through your Verathon Medical® Service Center in accordance to the WEEE requirements.

GlideScope® Warranty Offerings

Original First Year Total Customer CareSM Warranty

Verathon® warrants the GlideScope® System against defects in material and workmanship. This warranty applies for one (1) year from the date of shipment from Verathon®. This warranty is given only to the original purchaser of the GlideScope® System.

If a customer's system requires service or repair, Verathon® will either replace or provide a loaner unit within one (1) business day from the date of customer service notification. The customer agrees to send the defective unit to Verathon® upon receipt of the loaner unit and agrees to return the loaner unit within two (2) business days of receipt of the repaired unit.

- ◆ This warranty provides coverage for damage from accidental drops or mishandling. It does not cover damage due to deliberate mishandling.
- ◆ This warranty does not apply if the product has been damaged due to, or as the result of, service or modification by anyone other than an authorized Verathon® Service Center
- ◆ This warranty does not apply if there is evidence of the equipment being exposed to temperatures in excess of 60° C

The product shall be used in accordance with the instructions contained in this User's Manual. Consumable items (i.e., endotracheal tubes, Stats, stylets, etc.) shall be used in conformance to Verathon® product specifications. Consumable items are not covered under this warranty.

What is Covered

Warranty coverage is extended to the GlideScope® GVL® System:

- ◆ Video Monitor including Display Connector Cable and Video output Cable (VOC)
 - VOC is only covered with an extended warranty for the monitor
- ◆ GlideScope® Video Laryngoscopes (GVL®)
- ◆ Cobalt Video Batons

Additional GVLs® (laryngoscopes) purchased either singularly or as a part of a system must be warranted separately.

Additional video monitors purchased either singularly or as part of a system must be warranted separately.

Premium Customer CareSM Warranty

The Premium Customer CareSM warranty from Verathon Medical® may be extended for a total of up to six (6) years from date of purchase.

Disclaimer of Additional Warranties

There are no understandings, agreements, representations of warranties expressed or implied (including warranties of merchantability or fitness for a particular purpose) other than those set forth in the preceding Warranty section. The contents of this manual do not constitute a warranty.

Some states disallow certain limitations on applied warranties. The purchaser, user, and patient should consult state law if there is a question regarding this disclaimer. This information, descriptions, recommendations, and safety notations in this manual are based upon Verathon® experience and judgment with GlideScope® GVL® Systems as of September 2008. The contents of this manual should not be considered to be all-inclusive, or to cover all contingencies.

Contact Information

To obtain additional information regarding your GlideScope® Video Laryngoscope System, please contact Verathon Medical® Customer Care at:

**Corporate HQ:
(US and Canada)**
Verathon Inc.
20001 North Creek Parkway
Bothell, WA 98011-8128
USA
800.331.2313 (Canada and US)
425.867.1348
Fax: 425.883.2896
<http://www.verathon.com>

**Verathon Medical
(United Kingdom) Ltd.**
The Granary Manor Farm
Courtyard
Aston Sandford, Aylesbury
Buckinghamshire, HP17 8JB
United Kingdom
+44.1844.299.207
Fax: +44.1844.299.218
<http://www.verathon.co.uk/>

EC Rep

**Verathon Medical
(Europe) B.V.**
Boerhaaveweg 1
3401 MN IJsselstein
The Netherlands
+31.30.68.70.570
Fax: +31.30.68.70.512
<http://www.verathon.eu/>

**Verathon Medical
(Japan) K.K.**
Executive Tower Azabudai 7F
1-4-3 Azabudai
Minato-ku
Tokyo, Japan 106-0041
+81.03.3560.3501
Fax: +81.03.3560.3502

**Verathon Medical
(France) Sarl**
Espace Europeen de l'Entreprise
2 allée d'Oslo
BP 10039 Schiltigheim
F-67012 Strasbourg Cedex
France
+33.03.88.60.14.02
Fax: +33.(0)3.88.60.46.87

**Manufacturer:
Verathon Medical
(Canada) ULC**
4224 Manor Street
Burnaby, BC V5G 1B2
Canada
604.439.3009
Fax: 604.439.3039

Parts and Accessories

Table 3. GlideScope® System Components and Accessories.

Description	Part Number
GlideScope® Video Laryngoscope GVL® 5	0574-0030
GlideScope® Video Laryngoscope GVL® 4	0574-0001
GlideScope® Video Laryngoscope GVL® 3	0574-0007
GlideScope® Video Laryngoscope GVL® 2	0574-0010
GlideScope® Cobalt Video Baton 3-4	0570-0185
GlideScope® Cobalt Video Baton 1-2	0570-0210
GVL® Stat 4, Qty 10	0270-0444
GVL® Stat 3, Qty 10	0270-0446
GVL® Stat 2, Qty 10	0270-0429
GVL® Stat 1, Qty 10	0270-0428
GVL® Stat 4, Qty 100	0270-0445
GVL® Stat 3, Qty 100	0270-0447
GVL® Stat 2, Qty 100	0270-0431
GVL® Stat 1, Qty 100	0270-0430
Cobalt Video Baton 3-4 Kit (includes Stats)	0270-0382
Cobalt Video Baton 1-2 Kit (includes Stats)	0270-0608
Portable Video Monitor, GVL®	0231-0003
GlideRite® Rigid Stylet (Package of Six)	0803-0009
GlideScope® GVL® Cradle	0810-0126
GlideScope® Video Baton Cradle 3-4	0810-0134
GlideScope® Video Baton Cradle 1-2	0810-0151
Mobile Stand	0800-0299

Hard Shell Case	0800-0300
IV Pole Mounting Kit	0810-0125
O-Ring - Protective Cap	0120-0335
GlideScope® Video Cable - 3 pin to 4 pin	0600-0236
GlideScope® Video Cable - 4 pin to 4 pin	0600-0237
AC Power Cord 15 ft (4.5 m) - North America	0600-0244
AC Power Cord 2 ft (0.6 m) - North America	0600-0247
AC Power Cord 15 in (4.5 m) - EU	0600-0243
AC Power Cord 2 ft (0.6 m) - EU	0600-0246
AC Power Cord 15 ft (4.5 m) - UK	0600-0245
AC Power Cord 2 ft (0.6 m) - UK	0600-0248
Video output Cable (for connection to NTSC compatible devices)	0600-0239
GlideScope® Video Laryngoscope System User's Manual (English)	0900-1204
GlideScope® GVL®/Cobalt Cleaning and Assembly Quick Reference Card	0900-2013
GlideScope® Tips and Techniques Quick Reference Card with Ron Wall Technique	0900-1436
GlideScope® System Cleaning Poster	0900-1429

Specifications

Verathon® reserves the right to change specifications without notice.

General Specifications

Classification:	Electrical Class I, Applied Part BF
Line Voltage	Range: 100 – 240 VAC, 50 & 60 Hz
Line Current:	MAX 0.50 A
Power Plug:	Hospital Grade
Line Protection:	2A Fuse, Internal

Operating and Storage Conditions

Operating:	-4° F (-20° C) to 122° F (50° C)
Storage:	32° F (0° C) to 113° F (45° C)
Pollution Degree:	1

GlideScope® System Components

Portable Video monitor:

NTSC Color Video
320 x 240 pixel 7" LCD TFT Panel

Height:	6.57 in	167 mm
Width:	8.15 in	207 mm
Depth:	3.27 in	83 mm
Weight:	3.10 lb	1.4 kg



Mobile Stand:

Base height:	4.925 in	12.5 cm
Base weight:	5.5 lb	2.5 kg
Base diameter:	24 in	61 cm
Pole height range:	29.5-47 in	75-119 cm
Pole weight:	1.5 lb	0.7 kg



IV Pole Mount:

Weight:	2 lb	.9 kg
Arm Length:	10.63 in	27 cm
Width:	2.44 in	6.2 cm



GVL® 5

Tip to front of handle:	4 in	102 mm
Thickness (height) at camera:	.55 in	14 mm
Width of camera:	1.06	27 mm
Blade length in front of camera:	2.4 in	61 mm
Max blade width in front of camera:	1.06 in	27 mm



GVL® 4

Tip to front of handle:	4 in	102 mm
Thickness (height) at camera:	.55 in	14 mm
Width of camera:	1.06 in	27 mm
Blade length in front of camera:	2.4 in	61 mm
Max blade width in front of camera:	1.06 in	27 mm



GVL® 3

Tip to front of handle:	3.2 in	82 mm
Thickness (height) at camera:	.6 in	14.5 mm
Width of camera:	.7 in	7 mm
Blade length in front of camera:	2.1 in	52 mm
Max blade width in front of camera:	.75 in	19 mm



GVL® 2

Tip to front of handle:	3.2 in	82 mm
Thickness (height) at camera:	.57 in	14.5 mm
Width of camera:	.71 in	18 mm
Blade length in front of camera:	1.4 in	36 mm
Max blade width in front of camera:	.63 in	16 mm



GVL® Stat 4

Tip to front of handle:	3.7 in	95 mm
Thickness (height) at camera:	.63 in	16 mm
Width at camera:	.78 in	20 mm
Blade length in front of camera:	2.1 in	53 mm
Max blade width in front of camera:	1.1 in	27.5 mm



GVL® Stat 3:

Tip to front of handle:	3.15 in	80 mm
Thickness (height) at camera:	.63 in	16 mm
Width at camera:	.63 in	16 mm
Blade length in front of camera:	1.46 in	37 mm
Max blade width in front of camera:	.83 in	21 mm

**GVL® Stat 2:**

Tip to front of handle:	2 in	51 mm
Thickness (height) at camera:	.34 in	8.7 mm
Width at camera:	.43 in	10.9 mm
Blade length in front of camera:	1.10 in	28 mm
Max blade width in front of camera:	.63 in	16 mm

**GVL® Stat 1:**

Tip to front of handle:	1.50 in	38 mm
Thickness (height) at camera:	.34 in	8.7 mm
Width at camera:	.39 in	9.9 mm
Blade length in front of camera:	.59 in	15 mm
Max blade width in front of camera:	.51 in	13 mm

**Cobalt Video Baton 3-4:**

Length: Camera tip to SS ring:	4.1 in	104.1 mm
Height of camera:	.42 in	mm
Width of camera:	.43 in	10.7 mm
Cable length:	66 in	10.9 mm
Weight:	6.3 oz	1676 mm
		180 g

**Cobalt Video Baton 1-2:**

Length: Camera tip to handle (flexible tube)	1.57 in	40 mm
Height of camera:	.236 in	6 mm
Width of camera:	.276 in	7 mm
Cable length:	69 in	1756 mm
Weight:	4.6 oz	130 g



Standards and Approvals

- ◆ CMDCAS ISO 13485, Certificate No. 9235
- ◆ EC Certificate for Class I sterile Stats, Certificate No. 41315937
- ◆ MDD Requirements met for Class I and Class I sterile devices
- ◆ CSA Requirements met (Master Contract # 213281), CSA Certificates issued
- ◆ CB Scheme requirements met (CB Bulletin 112a), CB Test Certificates issued
- ◆ CAN/CSA C22.2 No 601.1-M90
- ◆ CAN/CSA C22.2 No. 60601-2-18-01
- ◆ UL Std No 60601-1
- ◆ IEC 60601-2-18
- ◆ CE Mark EMC Directive
- ◆ IEC 60601-1-2
- ◆ CISPR 11
- ◆ VCCI Technical V-3

Contact Information

Corporate HQ:

Verathon Incorporated
20001 North Creek Parkway
Bothell, WA 98011
USA
800.331.2313 (Canada and US)
425.867.1348
Fax: 425.883.2896
<http://www.verathon.com>

EC Rep**Verathon Medical (Europe) B.V.**







Boerhaaveweg 1
3401 MN IJsselstein
The Netherlands
+31.30.68.70.570
Fax: +31.30.68.70.512
<http://www.verathon.com.eu>

Manufacturer:**Verathon Medical (Canada) ULC**

4224 Manor Street
Burnaby, BC V5G 1B2
Canada
604.439.3009
Fax: 604.439.3039

Symbol Directory

Table 4. Symbol Directory.

Symbol	Meaning
	Type BF equipment
	CE mark in accordance with the Medical Device Directive. Class I Device.
	Canadian CSA Symbol
	FCC Symbol
	Attention – consult accompanying documents. Read instructions before connecting or operating.
	Subject to WEEE (Waste of Electronic Electrical Equipment) regulations.

